

 **XCMG** SALES  
& SERVICE

# XE19U

## MINI EXCAVATOR



[www.xcmgmachinery.com.au](http://www.xcmgmachinery.com.au)

## INDUSTRY EXPERTISE

XCMG Sales & Service is one of Australia's **fastest growing** construction and mining equipment suppliers.

Offering premium quality excavators, wheel loaders, compaction rollers, graders and access equipment, XCMG Sales & Service has **the products and the support** to keep you working on any job site.

## MACHINERY SALES

XCMG Sales & Service know construction and mining equipment. You can count on our **dedicated and knowledgeable team** of product experts to take the time to understand and satisfy your machinery needs by recommending the **right solution for the job**.

## RENTALS & HIRE

If you need a high-performance machine with reliability you can **trust**, and the flexibility of hiring, we have you covered.

Our fleet is diverse, with machines to suit almost any job. Furthermore, because our rental fleet is maintained by factory-trained technicians, you can be confident that you'll not only be getting the best machines on the market, but that it's going to **work as hard as you do**, day-in day-out.

## AFTERMARKET SUPPORT

We're here to help keep you and your machine working. With an **exceptional over-the-counter fill rate** on spare parts, you're assured that when you buy a machine from XCMG Sales & Service, you'll be looked after throughout your machine's entire lifetime, from start to finish.

Every service job is as important to us as it is to you, and with a dedicated team of machinery technicians, we have ample resources to look after any of your machine repairs or servicing requirements **quickly and efficiently**.

## ABOUT

**The World's 3rd largest manufacturer of construction and mining equipment.**

*Founded in 1943, 8 decades of experience.*

*Manufacturing in USA, Germany, China, Brazil and India.*

*Extensive supply chain and dealer network throughout Australia.*

*Deep relationships with corporate giants: Rio Tinto, BHP and MMG in Australia.*

## MINI / LARGE EXCAVATORS

*1 to 100+ Tonne*

## WHEEL LOADERS

*5 to 100 Tonne*

## COMPACTION ROLLERS

*1.5 to 30 Tonne Smooth & Padfoot*

## GRADERS

*7.5 to 70 Tonne*

## ACCESS EQUIPMENT

*Lift Heights from 5 to 21 Metres*



***“All branches offer sales, service, parts and rentals”***

***Qualified, expert Service Agents throughout all our territories.***

## **BRISBANE & SUNSHINE COAST (QLD)**

Our branches in Queensland, in Archerfield (Brisbane) and Chevallum (Sunshine Coast), are conveniently located to serve the entire state of Queensland.

Both branches offer complete sales, rentals, parts and service (in-house and field).

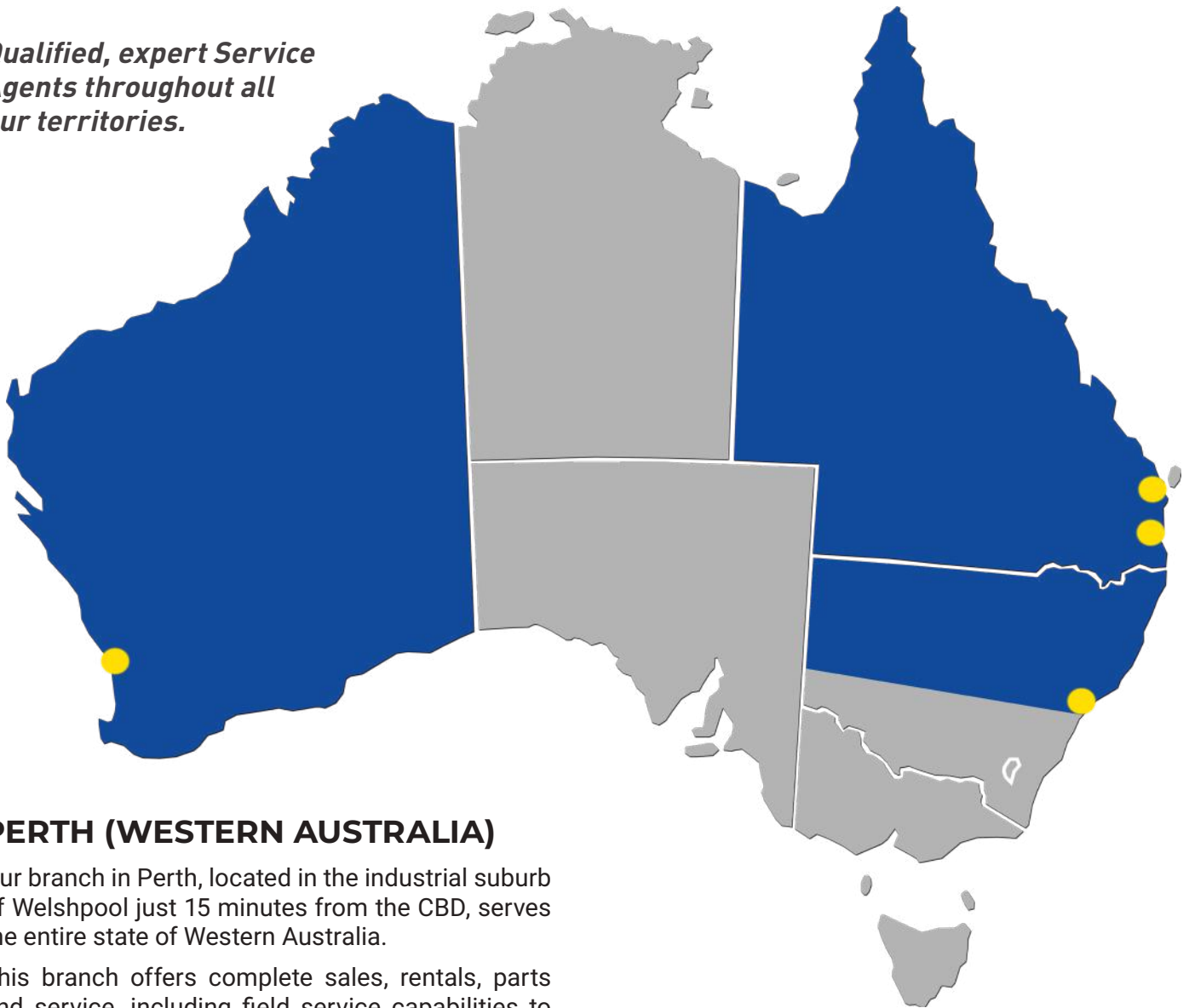

## **PERTH (WESTERN AUSTRALIA)**

Our branch in Perth, located in the industrial suburb of Welshpool just 15 minutes from the CBD, serves the entire state of Western Australia.

This branch offers complete sales, rentals, parts and service, including field service capabilities to the various mine sites throughout the state.

## **NEWCASTLE (NORTHERN NSW)**

Our branch in Newcastle, situated in Hexham on the Pacific Highway, serves the Northern NSW region from the Hawkesbury River north of Sydney, up to the Queensland border.

This branch acts as our headquarters, offering complete sales, service (in-house and field), rentals, parts and corporate shared services.

***“The specialists in whole-of-life support for your machine”***

# PERFORMANCE, RELIABILITY & VALUE

## GLOBAL DOMINANCE

XCMG is the World's 3rd largest construction machinery manufacturer, with dealerships, parts warehouses and service agents throughout Australia.

## ZERO TAILSWING

Operate with maximum performance, safety and efficiency in tight spaces thanks to the XE19U's zero tailswing design.

## OPEN CANOPY

ROPS, TOPS and OPG certified canopy is durable and robust to handle severe impact, ensuring your safety and peace of mind while operating, and also providing plenty of leg and arm room.

## INTELLIGENT DESIGN

With the touch of a button, the track gauge can be adjusted for tight spaces or operator preference, ensuring optimal digging performance.

## EXCEPTIONAL HYDRAULICS

Powerful and productive 50.6 LPM hydraulic system delivers exceptional flow rates to attachments, with 44.7 LPM oil flow on Auxiliary 1.

## EXTRA SAFETY FEATURES

XCMG has designed the XE19U with safety at the forefront, including an engine overheat warning, safety lever, travel alarm, rotating beacon, and rear view mirrors as standard.

*Designed to perform...*



# ***XE19U*** MINI EXCAVATOR

## **VISIBILITY PLUS**

In addition to the 360 degree visibility offered by the XE19U's clever open canopy design, also included as standard are front work lights for low light operation.

## **RELIABILITY & TRUST**

XCMG's key focus is the complete satisfaction and success of every machine owner and operator, making your business as profitable as possible.

## **KUBOTA ENGINE**

Renowned Kubota 20.9hp Euro Stage V emission certified engine delivering maximum power and torque plus exceptional reliability and longevity whilst offering low noise and vibration levels.

## **ERGONOMIC LAYOUT**

The XE19U is designed with the operator in mind, with perfectly set-out controls, ample leg and arm room, and a comfortable adjustable seat .

## **BOOM SWING**

The left and right boom swing angle supports complex operating conditions like parallel wall digging or working in narrow spaces.

## **UNMATCHED SUPPORT**

Product experts at your local dealer provide exceptional support throughout your machine's lifetime: operation, maintenance and service from the delivery date through to its very last day on the job.



***...built to  
last.***



Zero tailswing for tight access operation



Comfortable, ergonomic operator station



Efficient service access to all componentry



Boom cylinder above boom minimises risk of damage



Double flange track rollers



Mechanical hitch with easy access grease points



Bidirectional hydraulic piping



Hydraulic lines embedded in boom



Adjustable track width



Colour display screen

# XE19U MINI EXCAVATOR



## LIFTING CAPACITIES

Lift Point Height	Over Front				Over Side				Max Radius (mm)
	Lift at Max Radius (kg)	1m	2m	3m	Lift at Max Radius (kg)	1m	2m	3m	
2.5m	358.6				337				2739
2m	296.5			313.4	278.5			294.5	3109
1m	250		549.9	306.3	234.6		514	287.4	3455
0m	248.7		514.5	295.3	233.1		479.2	276.6	3413
-1	297.3	999	508.8		278.3	999	473.6		2963
-1.5m	*324.9	999	*466		*324.9	999	*466		2500

# XE19U SPECIFICATIONS

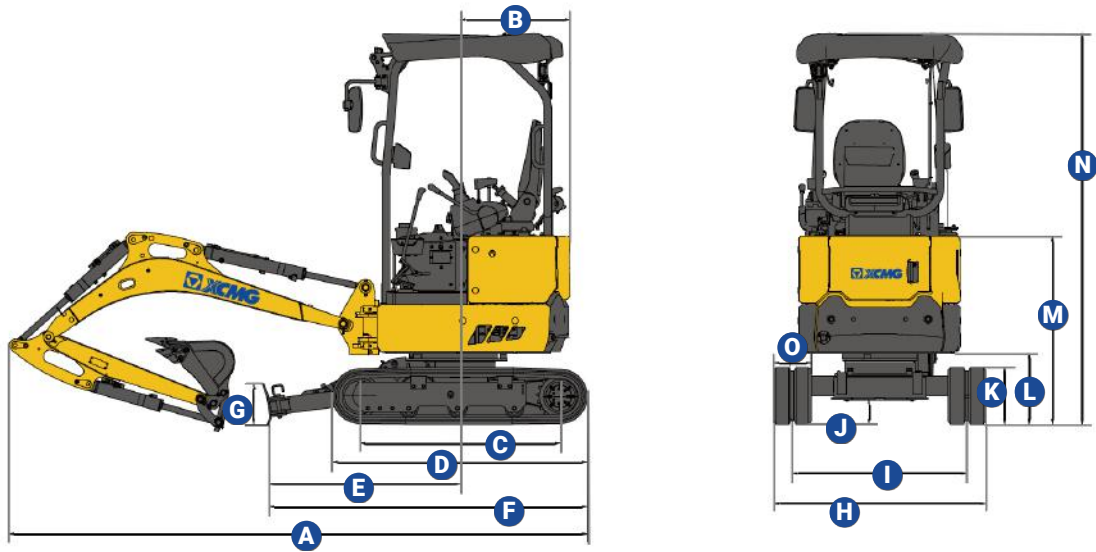

XE19U	A	B	C	D	E	F	G	H	I	J	K	L	M	N	O
mm	3550	675	1230	1565	1173	1953	248	990/1300	760/1070	147.5	345.5	433.5	1152	2395	230

## KEY PERFORMANCE SPECIFICATIONS

Key Specs	Operating Weight:	1900 kg
	Engine Model:	Kubota D1105 Euro Stage V
	Maximum Power:	20.9 hp / 15.4 kW @ 2400 rpm
	Maximum Torque:	70.3 nM / 1600 rpm
	Maximum Travel Speed:	4.4/2.5 km/h
	Tailswing Radius:	675 mm
	Boom Type:	Swing Boom
	Dipper / Boom Length:	1090mm / 1810mm
	Boom Cylinder:	Above Boom
	Bucket / Arm Digging Forces:	16 / 10 kN
	Swing Speed:	10 rpm
	Maximum Dig Reach / Depth:	4055 mm / 2520 mm
Maximum Dump Height:	2455 mm	
Operator Station	Canopy / Cabin Type:	Open Canopy
	Canopy / Cabin Safety:	ROPS / TOPS / OPG
	Seat:	Suspension
Hydraulics	Joystick Controls:	Yes, Included as Standard
	Pump Type:	Load-Sensing Axial Piston Pump w/ Variable Displacement
	Pump Make:	CASAPPA
	Slew Pump Make:	Eaton
	Drive Motor Make:	XCMG
	Hydraulic Piping:	Single / Bidirectional
	Hydraulic System Flow:	50.6 LPM
Hydraulic Aux1 Flow:	44.7 LPM	
Additional Features	Track Shoes:	230mm Rubber
	Dozer Blade:	Yes, Included as Standard
	Canopy:	Yes, Included as Standard
	Amber Rotating Beacon:	Yes, Included as Standard
	Emergency Stop:	Yes, Included as Standard
	Rear View Mirrors:	Left + Right
Hitch Type:	Mechanical Quick Hitch	

Note: specifications listed above are correct at April 2023 and are subject to change any time. For additional information visit [www.xcmgmachinery.com.au](http://www.xcmgmachinery.com.au).